

LP5522

Programmable LED Driver

General Description

The LP5522 is a simple single wire programmable LED controller in six bump micro SMD package. It provides constant current flow through high side driver. Output current can be set from 1 mA to 20 mA by using an external resistor on the ISET pin. If no external resistor is used, output current is set to 5 mA default current. The LP5522 is controlled using only one signal. The signal controls either directly the LED driver or it launches previously programmed blinking sequence.

The LP5522 works autonomously without a clock signal from the master device. Very low LED driver headroom voltage makes possible to use supply voltages close to LED forward voltage. Current consumption of the LP5522 is minimized when LED is turned off and once controller is disabled all supporting functions are also shut down. Very small micro SMD package together with minimum number of external components is a best fit for handheld devices.

Features

- Programmable blinking sequence
 - 1 to 3 programmable pulses
 - 1 ms to 255 ms LED on time
 - 10 ms to 2500 ms LED off time
 - Single or continuous run of programmed blinking sequence
- Constant current high side output driver
- Adjustable current with external resistor
- 0.2 uA typical shutdown current
- Autonomous operation without external clock
- Micro SMD-6 package with 0.4 mm pitch:
1.215 mm x 0.815 mm x 0.6 mm (LxWxH)

Applications

- Indicator lights
- Phone cosmetics
- Toys

Typical Application

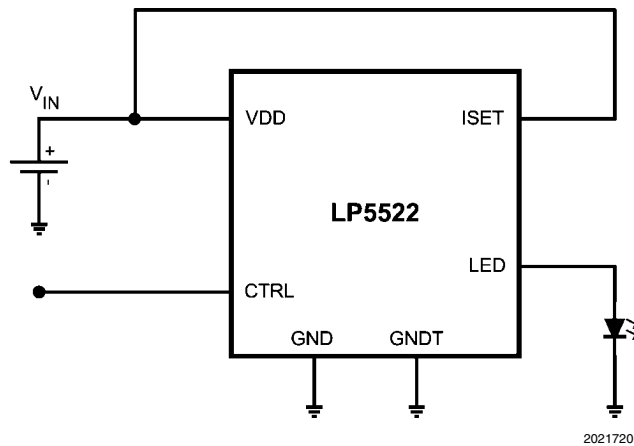

Connection Diagrams and Package Mark Information

Connection Diagrams

Micro SMD-6 package, 0.815 x 1.215 x 0.60 mm body size, 0.4 mm pitch NS Package Number TMD06AAA

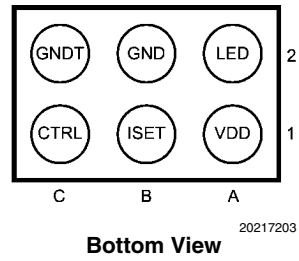
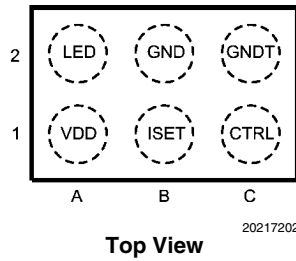

PACKAGE MARK

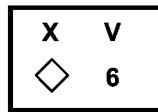

X = 1 Digit Date Code
 V = Die Traceability
 6 = Product Identification
 ◊ = Pin A1

20217204

ORDERING INFORMATION

Order Number	Package Marking	Supplied As	Spec/Flow
LP5522TM	6	TNR 250	NOPB
LP5522TMX	6	TNR 3000	NOPB

PIN DESCRIPTIONS

Pin	Name	Type	Description
A1	VDD	P	Power supply pin
B1	ISET	AI	Current set input
C1	CTRL	DI	Digital control input
A2	LED	AO	Current source output
B2	GND	G	Ground
C2	GNDT	G	Ground

A: Analog Pin **D:** Digital Pin **G:** Ground Pin **P:** Power Pin

I: Input Pin **O:** Output Pin

Absolute Maximum Ratings (Notes 1, 2)

If Military/Aerospace specified devices are required, please contact the National Semiconductor Sales Office/Distributors for availability and specifications.

V (VDD, LED, ISET)	-0.3V to +6.0V
Voltage on logic pin (CTRL)	-0.3V to VDD +0.3V with 6.0V max
Continuous Power Dissipation (Note 3)	Internally Limited
Junction Temperature (T_{J-MAX})	125°C
Storage Temperature Range	-65°C to +150°C
Maximum Lead Temperature (Reflow soldering, 3 times) (Note 4)	260°C
ESD Rating (Note 5)	
Human Body Model	2 kV

Operating Ratings (Notes 1, 2)

Voltage on power pin (VDD)	2.7V to 5.5V
Recommended Load Current	1 mA to 20 mA
Junction Temperature (T_J) Range	-30°C to +125°C
Ambient Temperature (T_A) Range (Note 6)	-30°C to +85°C

Thermal Properties

Junction-to-Ambient Thermal Resistance (θ_{JA}), TMD06 Package (Note 7)	87°C/W
--	--------

Electrical Characteristics (Notes 2, 8)

Limits in standard typeface are for $T_J = 25^\circ\text{C}$. Limits in **boldface** type apply over the operating ambient temperature range ($-30^\circ\text{C} < T_A < +85^\circ\text{C}$). Unless otherwise noted, specifications apply to the LP5522 Block Diagram with: $V_{IN} = 3.6\text{V}$, $R_{ISET} = 24\text{ k}\Omega$, $C_{IN} = 100\text{ nF}$.

Symbol	Parameter	Condition	Min	Typ	Max	Units
I_{VDD}	Standby supply current	CTRL = L		0.2	1	μA
	Active Mode Supply Current	CTRL = H, LED = off		40	55	μA
$I_{LEAKAGE}$	LED Pin Leakage Current				1	μA
I_{OUT}	LED Output Current	Without external resistor	-8	5	+8	mA %
	LED Output Current	With external 24k Ω 0.04% resistor	-8	20	+8	mA %
I_{MIRROR}	External R_{ISET} Mirroring Ratio			1:400		
V_{ISET}	ISET Reference Voltage			1.23		V
V_{HR}	Minimum Headroom Voltage ($V_{IN} - V_{LED}$) (Note 9)	I_{OUT} set to 10 mA		35	50	mV
		I_{OUT} set to 20 mA		70	100	mV
T_{CYCLE_H}	Minimum LED On Time		0.9	1.0	1.1	ms
T_{CYCLE_L}	Minimum LED Off Time		9	10	11	ms
$ON_{RESOLUTION}$	LED On Time Resolution			1		ms
$OFF_{RESOLUTION}$	LED Off Time Resolution			10		ms
$T_{Timeout_H}$	LED Timeout On Time		287	319	351	ms
$T_{Timeout_L}$	LED Timeout Off Time		2.87	3.19	3.51	s
V_{IL}	Logic Input Low Level				0.5	V
V_{IH}	Logic Input High Level		1.2			V
I_{IN}	CTRL Input Current		-1		1	μA
t_{ON}	CTRL Pulse ON Time		15			μs
t_{OFF}	CTRL Pulse OFF Time		30			μs
t_{ENTER}	Command Entering Period		500			μs
$t_{ENTER} + t_{BLANK}$	Command Entering Period + Blank Period				1500	μs

Note 1: Absolute Maximum Ratings indicate limits beyond which damage to the component may occur. Operating Ratings are conditions under which operation of the device is guaranteed. Operating Ratings do not imply guaranteed performance limits. For guaranteed performance limits and associated test conditions, see the Electrical Characteristics tables.

Note 2: All voltages are with respect to the potential at the GND pins.

Note 3: Internal thermal shutdown circuitry protects the device from permanent damage. Thermal shutdown engages at $T_J = 160^\circ\text{C}$ (typ.) and disengages at $T_J = 140^\circ\text{C}$ (typ.).

Note 4: For detailed soldering specifications and information, please refer to National Semiconductor Application Note AN1112 : Micro SMD Wafer Level Chip Scale Package.

Note 5: The Human body model is a 100 pF capacitor discharged through a 1.5 kΩ resistor into each pin. MIL-STD-883 3015.7

Note 6: In applications where high power dissipation and/or poor package thermal resistance is present, the maximum ambient temperature may have to be derated. Maximum ambient temperature (T_{A-MAX}) is dependent on the maximum operating junction temperature ($T_{J-MAX-OP} = 125^{\circ}C$), the maximum power dissipation of the device in the application (P_{D-MAX}), and the junction-to ambient thermal resistance of the part/package in the application (θ_{JA}), as given by the following equation: $T_{A-MAX} = T_{J-MAX-OP} - (\theta_{JA} \times P_{D-MAX})$.

Note 7: Junction-to-ambient thermal resistance is highly application and board-layout dependent. In applications where high maximum power dissipation exists, special care must be paid to thermal dissipation issues in board design.

Note 8: Min and Max limits are guaranteed by design, test, or statistical analysis. Typical numbers are not guaranteed, but do represent the most likely norm.

Note 9: The current source is connected internally between V_{IN} and V_{LED} . The voltage across the current source, ($V_{IN} - V_{LED}$), is referred to a headroom voltage (V_{HR}). Minimum headroom voltage is defined as the V_{HR} voltage when the LED current has dropped 10% from the value measured at $V_{LED} = V_{IN} - 1V$.

LP5522 Block Diagram

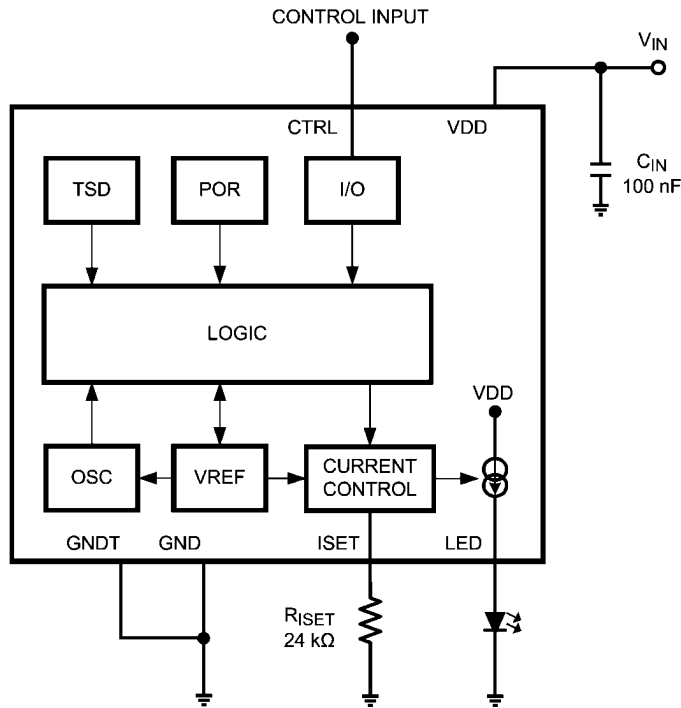

202172306

Modes of Operation

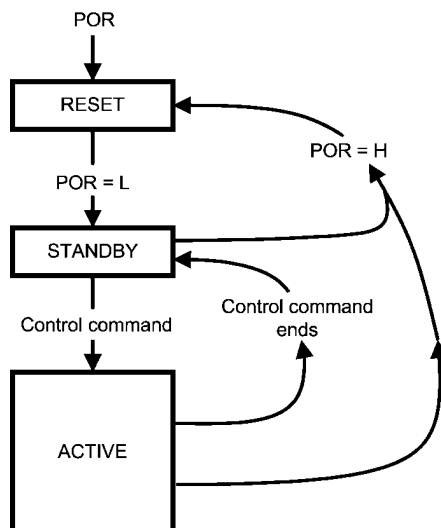

20217206

RESET

In the reset mode all functions are off and all registers are reset to the default values. Reset is entered always if internal Power On Reset (POR) is active. Power On Reset will activate during the device startup or when the supply voltage V_{IN} falls below 1.5V (typ.).

STANDBY:

After Power On Reset device is in Standby mode. This is the low power consumption mode, when all circuit functions are disabled.

ACTIVE:

Once rising edge of CTRL signal is detected device goes into Active mode. In Active mode four sub modes are present:

RUN:

Run mode is divided into two sub modes depending on whether a blinking sequence is programmed into memory or not.

Non-programmed mode:

No blinking sequence programmed to memory. LED output follows CTRL input

Programmed mode:

Blinking sequence programmed to memory. LED output follows the programmed blinking sequence

RUN ONCE:

In Run once mode, programmed blinking sequence is performed once and after that device returns into Standby mode. Run once mode is available only if a blinking sequence is programmed into memory.

TRAINING:

In Training mode new blinking sequence can be programmed. LED output follows CTRL signal during the programming

TSD:

If chip temperature rises above 160°C (typ.) device goes into Thermal Shut Down (TSD) mode. In TSD mode output is disabled but supporting functions are on.

LED Driver Operational Description

The LP5522 LED driver is constant current source. Current can be set with external resistor (R_{ISET}) so that the current ratio between resistor and LED is 1:400. R_{ISET} current correlates to ISET reference voltage (V_{ISET}). Consequently, current through LED can be adjusted using equation $I_{OUT} = 480/R_{ISET}$.

Use of external resistor is optional. If external resistor is not connected, default output current is 5 mA. When external resistor is not used ISET pin should be connected to VDD.

LED Driver Typical Performance Characteristics

$T_J = 25^\circ\text{C}$. Unless otherwise noted, typical performance characteristics apply to the LP5522 Block Diagram with: $V_{IN} = 3.6\text{V}$, $R_{ISET} = 24\text{ k}\Omega$, $C_{IN} = 100\text{ nF}$.

Output Current vs R_{ISET} (Expanded Range)

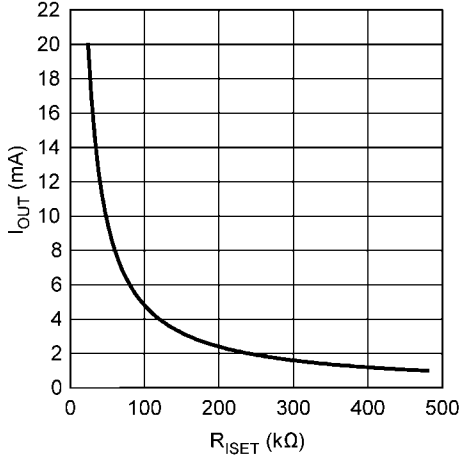

20217299

Output Current vs R_{ISET}

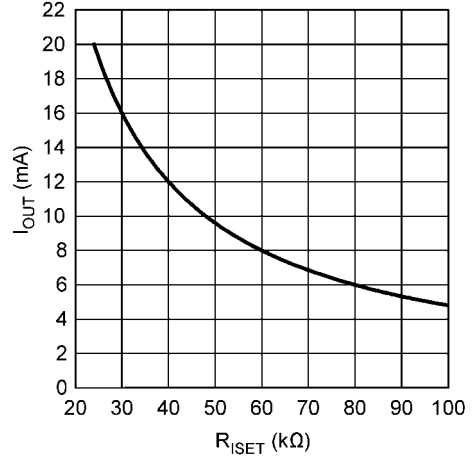

202172300

Output Current vs Input Voltage (ISET Connected To VDD)

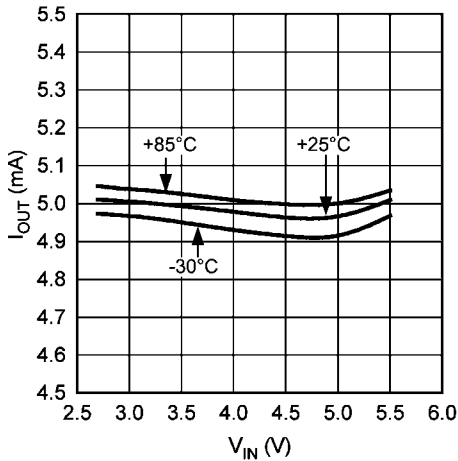

202172301

Output Current vs Headroom Voltage

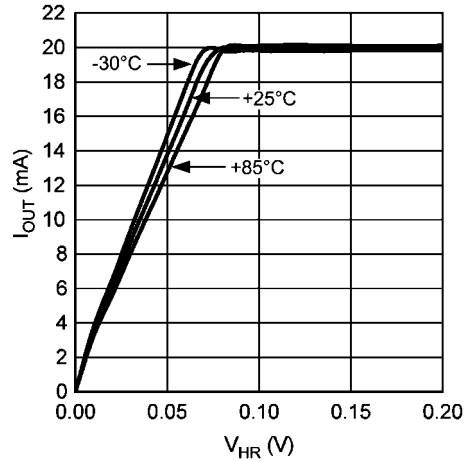

202172302

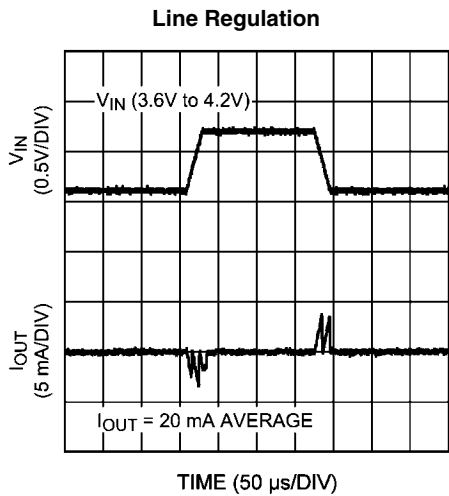

202172305

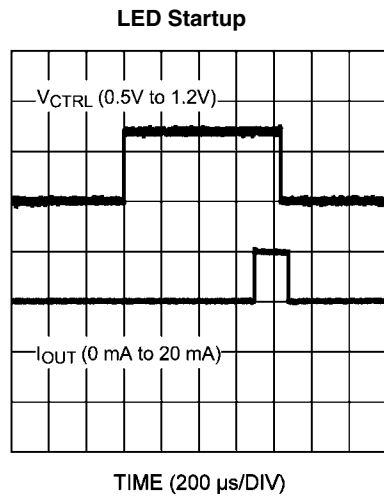

202172304

Control Interface Operational Description

LP5522 has one digital control input, CTRL. Threshold levels of CTRL input are fixed to enable control from low voltage controller. CTRL signal is used to control the mode of the circuit. A rising edge of the CTRL signal activates the circuit and starts a command entering period. During the command entering period all rising edges are counted. After command entering period there is a blank period when no rising edges are allowed. If CTRL is left high after command entering period, the consequent command is performed right after the blank period.

Note that timing diagrams are not on scale!

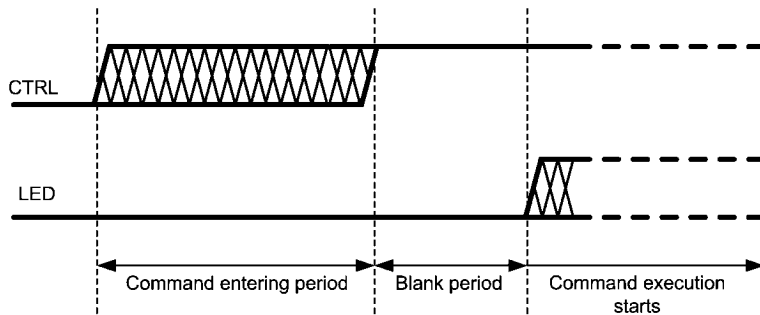

20217298

If CTRL signal is low after command entering period, command execution starts when CTRL is pulled high. This does not apply to Run command. With Run command CTRL must be high. Note that no rising edges are allowed during blank period.

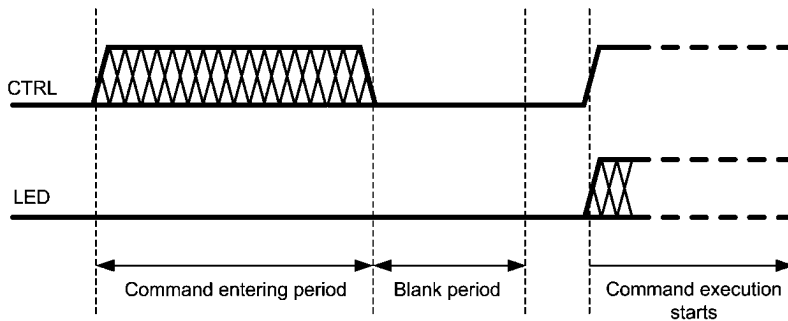

20217285

LED Controller Commands and Operation

There are four commands available for LP5522.

Command	Number of rising edges during command entering period
Run	One rising edge
Training start	Two rising edges
Training end	Three rising edges
Run once	Four rising edges

RUN COMMAND

One rising edge of CTRL signal within command entering period is interpreted as Run command. In programmed mode blinking sequence is started right after Blank period and it is repeated as long as CTRL signal is kept high. When CTRL signal is set low device goes into Standby mode.

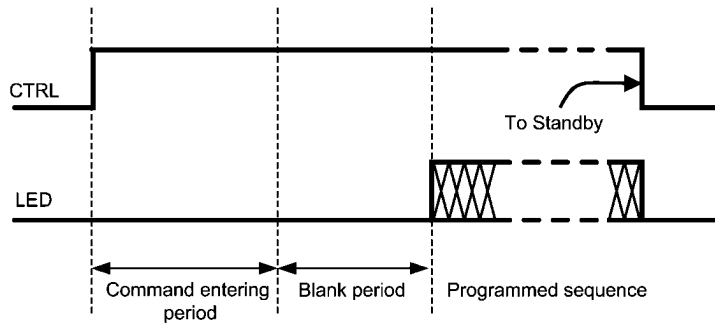

20217216

In non-programmed mode LED is on as long as CTRL is kept high. When CTRL signal is set low device goes into Standby mode.

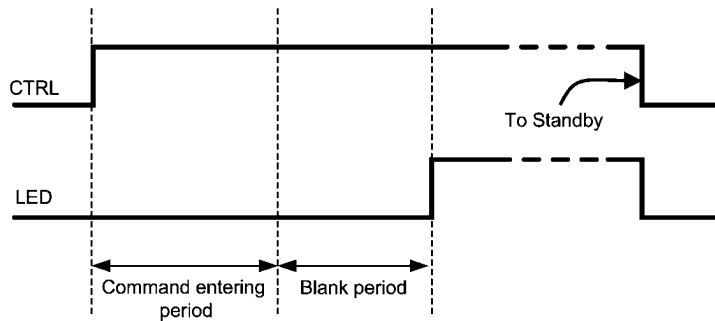

20217249

RUN ONCE COMMAND

Programmed blinking sequence is performed once after Run Once command. Four rising edges of CTRL signal within command entering period is interpreted as Run Once command. If CTRL is kept high after command entering period the programmed blinking sequence starts right after the blank period has elapsed. CTRL signal must stay high as long as programmed blinking sequence is executed. If CTRL is set low during execution of blinking sequence, device goes to standby and execution of blinking sequence is stopped.

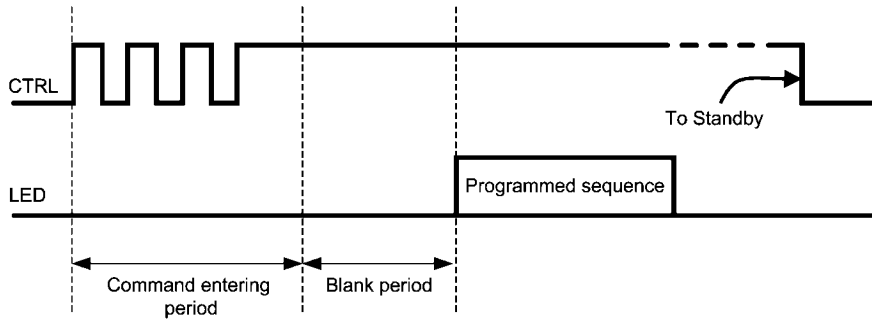

20217219

If CTRL signal is low after command entering period, Run Once command is executed once the CTRL is set high.

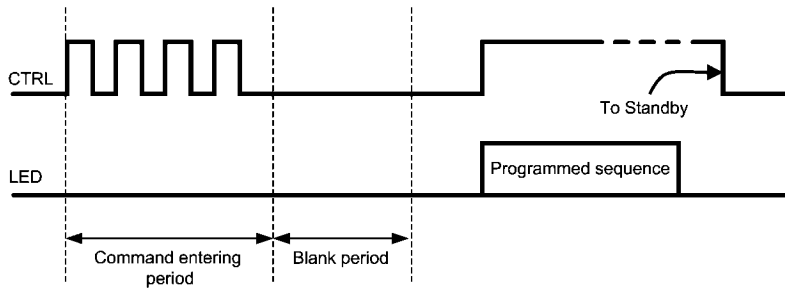

20217250

TRAINING START COMMAND

Blinking sequence is programmed into memory in training mode. Blinking sequence is stored into volatile memory, thus removing input voltage V_{IN} resets the memory. Memory can also be reset by giving Training Start and Training End commands without any valid LED ON/OFF times.

LP5522 enters to Training mode after Training Start command. Two rising edges within command entering period is interpreted as the Training Start command. The first LED ON time capturing is started once the rising edge of CTRL signal is detected after the blank period. LED output follows CTRL signal during the programming.

The first LED ON time is recorded once CTRL signal is set low. Same time the first LED OFF time capturing is started. Programmed blinking sequence can have one to three LED ON/OFF times. In order to be programmed correctly, at least one valid LED ON and LED OFF time must be recorded.

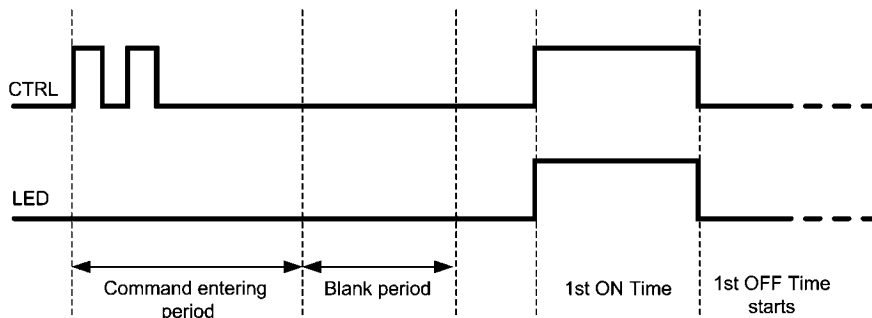

20217251

TRAINING END COMMAND

Blinking sequence programming ends once Training End command is introduced. Three rising edges within time period of t_{ENTER} is interpreted as Training End command. Note that blank period is also required after Training End command. During blank period no rising edges are allowed.

When Training End command is introduced during LED OFF time capturing, LED OFF time is recorded and chip goes to standby mode.

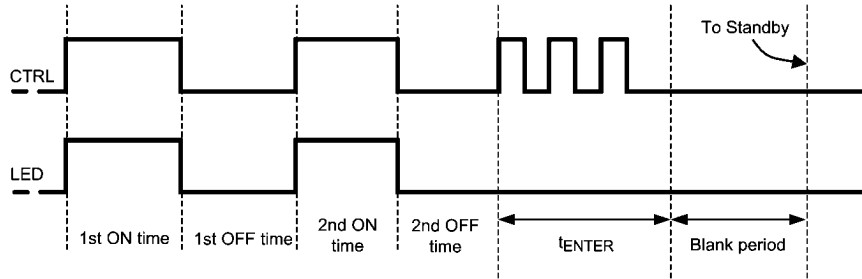

20217218

If Training End command is introduced during LED ON time capturing, the associated LED ON period is not recorded and hence neither OFF time. Notice that valid OFF time before Training End is longer than half of Minimum LED OFF period (T_{CYCLE_L}).

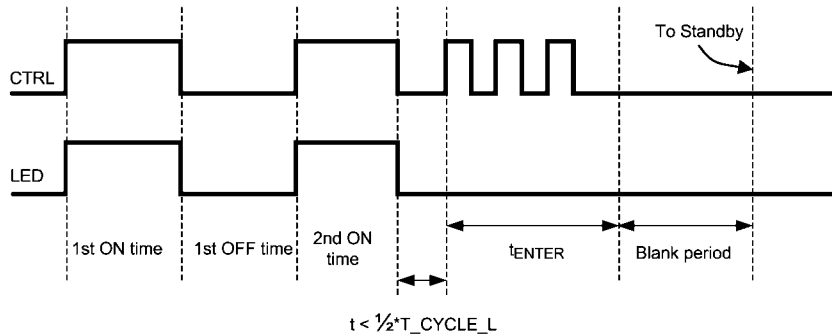

20217254

LED TIMEOUT ON/OFF TIMES

When LP5522 is in training mode and CTRL signal is high longer than LED Timeout ON time, the ON time counter saturates. In this case saturated ON time is recorded and LED OFF time capturing is started. At the same time LED is switched off even if the CTRL signal is still high.

If ON time counter has saturated, LED OFF time recording is terminated either by giving a Train End command or setting the CTRL signal to low and back to high. Setting the CTRL signal back to high records the LED OFF time and starts next ON time capturing.

If anyhow CTRL is still high after the LED Timeout OFF time has been elapsed the OFF time counter saturates and saturated OFF time is recorded. After that chip waits the CTRL signal to go low which cause the chip to go Standby.

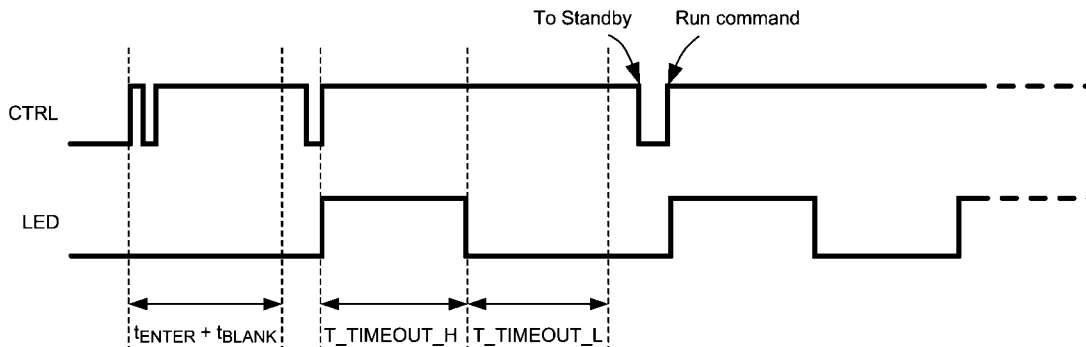

20217220

LED OFF time counter can saturate also if Training end command is not given or no new ON time has been started. In this case saturated OFF time is recorded and chip goes to Standby.

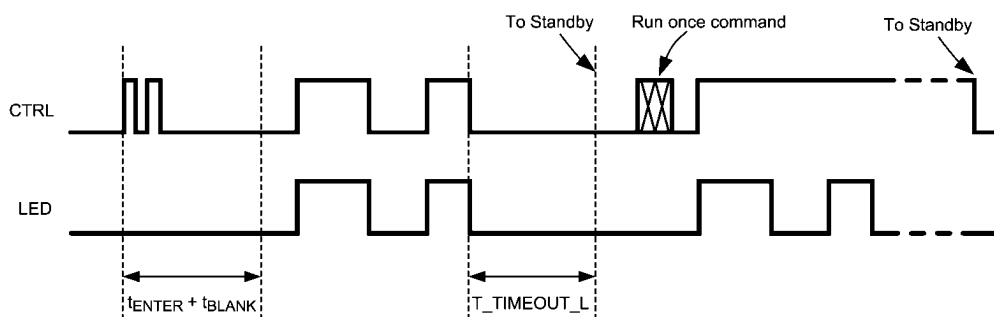

20217217

Recommended External Components

INPUT CAPACITOR, C_{IN}

Although not required for normal operation, a capacitor can be added to V_{IN} to reduce line noise. A surface-mount multi-layer ceramic capacitor (MLCC) is recommended. MLCCs with a X7R or X5R temperature characteristic are preferred.

CURRENT SET RESISTOR, R_{ISET}

If other than 5 mA current is required, R_{ISET} resistor can be used to adjust the current. For 20 mA current 24 k Ω resistor

is required. Accuracy of the resistor directly effects to the accuracy of the LED current. 1% or better is recommended.

LED

Forward voltage of LED must be less than minimum input voltage minus minimum headroom voltage (V_{HR}). For example with 2.7V input voltage and 20 mA LED current the maximum LED forward voltage is 2.7V - 100 mV = 2.6V.

List of Recommended External Components

Symbol	Symbol Explanation	Value	Unit	Type
C_{IN}	VDD Bypass Capacitor	100	nF	Ceramic, X7R or X5R
R_{ISET}	Current Set Resistor for 20 mA LED Current	24	k Ω	1%
LED		User defined		

Physical Dimensions inches (millimeters) unless otherwise noted

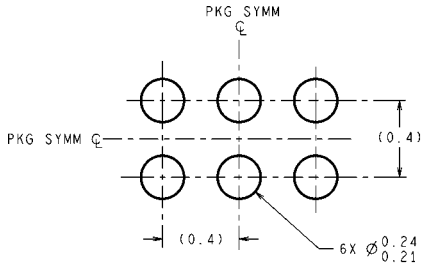

DIMENSIONS ARE IN MILLIMETERS
DIMENSIONS IN () FOR REFERENCE ONLY

LAND PATTERN RECOMMENDATION

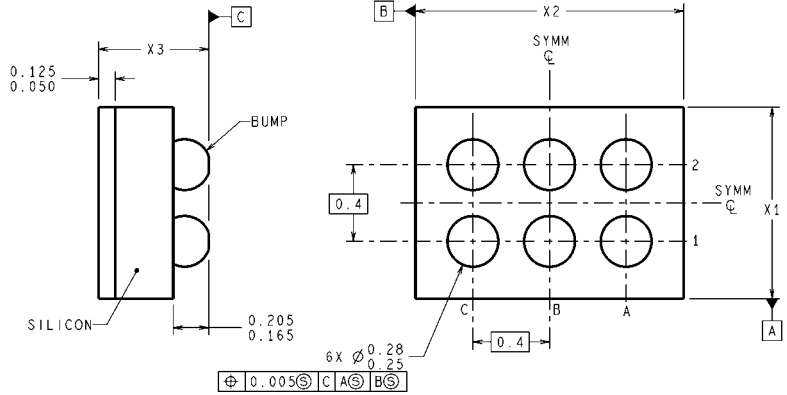
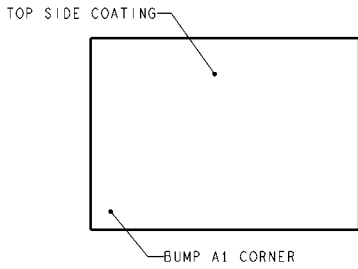

TMD06XXX (Rev B)

The dimension for X1, X2 and X3 are as given:

- X1 = 0.815 mm ±0.03 mm
- X2 = 1.215 mm ±0.03 mm
- X3 = 0.60 mm ±0.075 mm

NS Package Number TMD06AAA
microSMD-6

See National Semiconductor Application Note 1112 Micro SMD Wafer Level Chip Scale Package for PCB design and assembly instructions.

Notes

Notes

THE CONTENTS OF THIS DOCUMENT ARE PROVIDED IN CONNECTION WITH NATIONAL SEMICONDUCTOR CORPORATION ("NATIONAL") PRODUCTS. NATIONAL MAKES NO REPRESENTATIONS OR WARRANTIES WITH RESPECT TO THE ACCURACY OR COMPLETENESS OF THE CONTENTS OF THIS PUBLICATION AND RESERVES THE RIGHT TO MAKE CHANGES TO SPECIFICATIONS AND PRODUCT DESCRIPTIONS AT ANY TIME WITHOUT NOTICE. NO LICENSE, WHETHER EXPRESS, IMPLIED, ARISING BY ESTOPPEL OR OTHERWISE, TO ANY INTELLECTUAL PROPERTY RIGHTS IS GRANTED BY THIS DOCUMENT.

TESTING AND OTHER QUALITY CONTROLS ARE USED TO THE EXTENT NATIONAL DEEMS NECESSARY TO SUPPORT NATIONAL'S PRODUCT WARRANTY. EXCEPT WHERE MANDATED BY GOVERNMENT REQUIREMENTS, TESTING OF ALL PARAMETERS OF EACH PRODUCT IS NOT NECESSARILY PERFORMED. NATIONAL ASSUMES NO LIABILITY FOR APPLICATIONS ASSISTANCE OR BUYER PRODUCT DESIGN. BUYERS ARE RESPONSIBLE FOR THEIR PRODUCTS AND APPLICATIONS USING NATIONAL COMPONENTS. PRIOR TO USING OR DISTRIBUTING ANY PRODUCTS THAT INCLUDE NATIONAL COMPONENTS, BUYERS SHOULD PROVIDE ADEQUATE DESIGN, TESTING AND OPERATING SAFEGUARDS.

EXCEPT AS PROVIDED IN NATIONAL'S TERMS AND CONDITIONS OF SALE FOR SUCH PRODUCTS, NATIONAL ASSUMES NO LIABILITY WHATSOEVER, AND NATIONAL DISCLAIMS ANY EXPRESS OR IMPLIED WARRANTY RELATING TO THE SALE AND/OR USE OF NATIONAL PRODUCTS INCLUDING LIABILITY OR WARRANTIES RELATING TO FITNESS FOR A PARTICULAR PURPOSE, MERCHANTABILITY, OR INFRINGEMENT OF ANY PATENT, COPYRIGHT OR OTHER INTELLECTUAL PROPERTY RIGHT.

LIFE SUPPORT POLICY

NATIONAL'S PRODUCTS ARE NOT AUTHORIZED FOR USE AS CRITICAL COMPONENTS IN LIFE SUPPORT DEVICES OR SYSTEMS WITHOUT THE EXPRESS PRIOR WRITTEN APPROVAL OF THE CHIEF EXECUTIVE OFFICER AND GENERAL COUNSEL OF NATIONAL SEMICONDUCTOR CORPORATION. As used herein:

Life support devices or systems are devices which (a) are intended for surgical implant into the body, or (b) support or sustain life and whose failure to perform when properly used in accordance with instructions for use provided in the labeling can be reasonably expected to result in a significant injury to the user. A critical component is any component in a life support device or system whose failure to perform can be reasonably expected to cause the failure of the life support device or system or to affect its safety or effectiveness.

National Semiconductor and the National Semiconductor logo are registered trademarks of National Semiconductor Corporation. All other brand or product names may be trademarks or registered trademarks of their respective holders.

Copyright© 2007 National Semiconductor Corporation

For the most current product information visit us at www.national.com



National Semiconductor Americas Customer Support Center
 Email: new.feedback@nsc.com
 Tel: 1-800-272-9959

National Semiconductor Europe Customer Support Center
 Fax: +49 (0) 180-530-85-86
 Email: europe.support@nsc.com
 Deutsch Tel: +49 (0) 69 9508 6208
 English Tel: +49 (0) 870 24 0 2171
 Français Tel: +33 (0) 1 41 91 8790

National Semiconductor Asia Pacific Customer Support Center
 Email: ap.support@nsc.com

National Semiconductor Japan Customer Support Center
 Fax: 81-3-5639-7507
 Email: jpn.feedback@nsc.com
 Tel: 81-3-5639-7560